

# The X37 Series

**SAFELINE**  
X-ray Inspection



## **X37 Series**

X3710 X-ray System

X3720 X-ray System

X3725 X-ray System

X3730 X-ray System

X3735 X-ray System

X3750 X-ray System



## **X37 Series of X-ray Systems** Inspection of Tall, Rigid Containers

**METTLER TOLEDO**

## X37 Series

# The Big Difference is in Every Detail

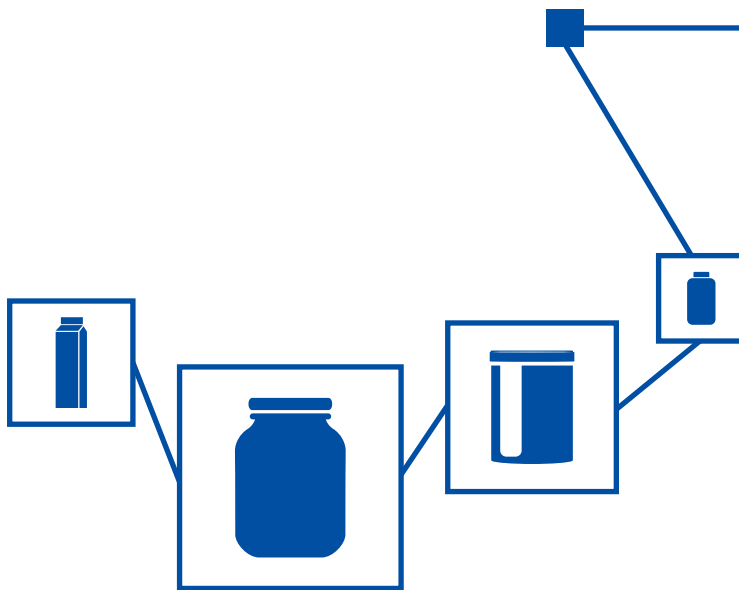

**The X37 Series offers the most technically advanced x-ray inspection system on the market for tall, rigid containers. It provides a competitive advantage to food and pharmaceutical manufacturers, by providing a highly adaptable solution to suit individual applications, by offering a wide range of features, combined with low-power consumption, making the X37 a future-proof investment.**

An improved user experience and a highly-functional design makes the X37 Series truly market-facing and encapsulates the most advanced development in inspection capability, reducing the Total Cost of Ownership (TCO) and providing customers with the tools to achieve compliance with industry standards.

With a choice of detectors and generators, the X37 offers outstanding detection sensitivity of contaminants, including glass, metal, calcified bone, high-density plastics and rubbers. Each contaminant can be detected in a range of packaging types such as metal can, glass and plastic containers, as well as doypacks, cartons, and composite cans/tubes. Simultaneously, multiple product integrity checks can be performed, offering not just product safety but complete brand protection.



## Model and Application Overview

X-ray Inspection System	Generator			Detector*
	20W	100W	420W	0.8mm
X3710	•			•
X3720		•	•	•
X3725		•	•	•
X3730		•	•	•
X3735		•	•	•
X3750			•	•

Packaging Type	Recommended System					
	X3710	X3720	X3725	X3730	X3735	X3750
Composite Cans/Cartons/Tubes	•	•	•			
Plastic Containers	•	•	•			
Doypacks	•	•	•			
Metal Containers		•	•	•	•	
Glass Containers				•	•	•
Ceramic Containers				•	•	

\* 0.4mm detector available upon request

Please note that the above table is for indication purposes only, please contact your local sales representative for more information.

# X37 Features & Benefits

## The Big Difference is in Every Detail



**Multiple Detector Options**  
0.4mm/0.8mm diode size options are available to best fit the customer's application and inspection requirements.

**Low, Medium and High-Powered Generators**  
No active cooling required on machines where the 20W generator is applicable, reducing power consumption and maintenance costs.

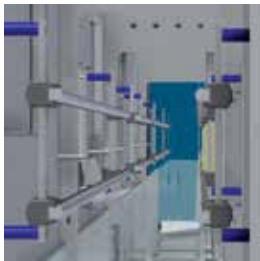
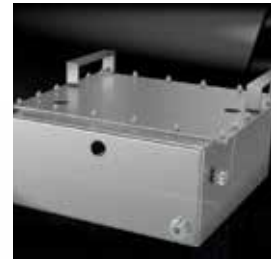

**Full-Length Guide Rails**  
Adjustable and product specific guide rails offer quick and easy product set-up and change-over.

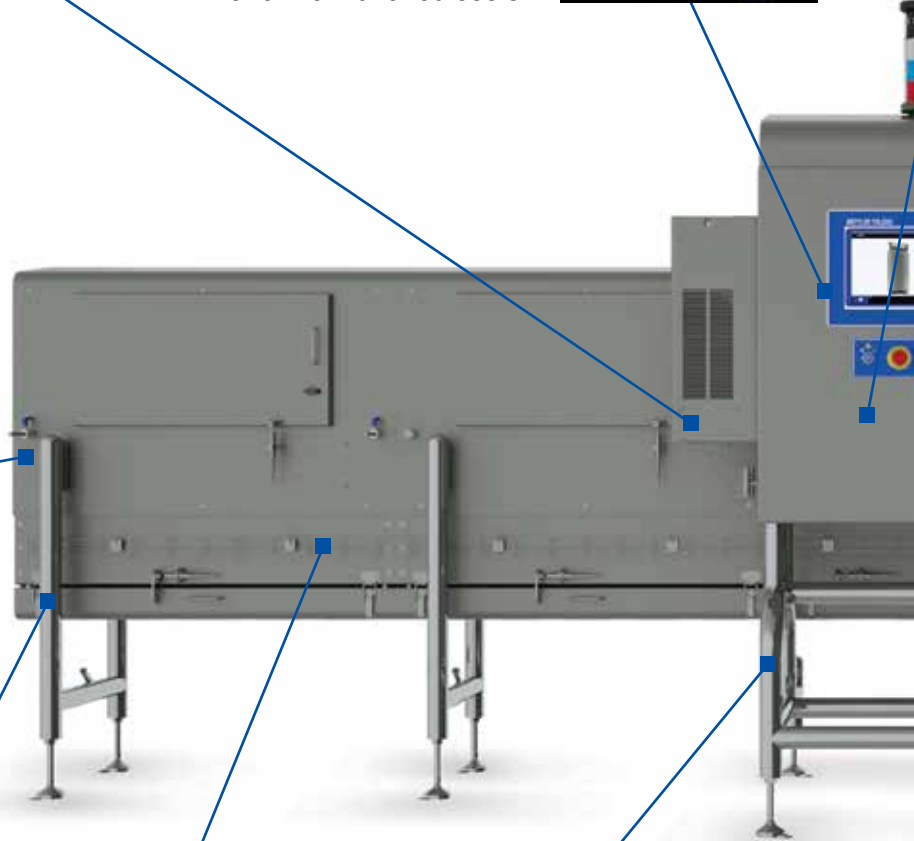

**Throughput Capabilities**  
Capable of inspecting up to 1,200 containers per minute depending on application.



**Outside Cable Trays**  
Avoiding bacteria traps and facilitating customer's existing cables.

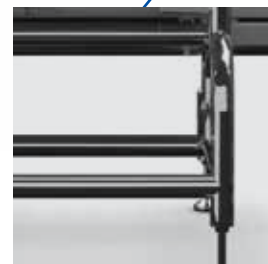

**Robust Tubular Hygienic Frame Design**  
Hygienic design allows for water to roll off during cleaning.



### Diverse Connectivity Options

Allows multiple methods to interact with the system and retrieve statistics/ images including PackML.



### Full Range of Inspection Tools

Simultaneously inspects products for contamination and product integrity to ensure brand protection.



### Magnetic Safety Switches

Open access doors are easily and quickly identified, ensuring uptime.

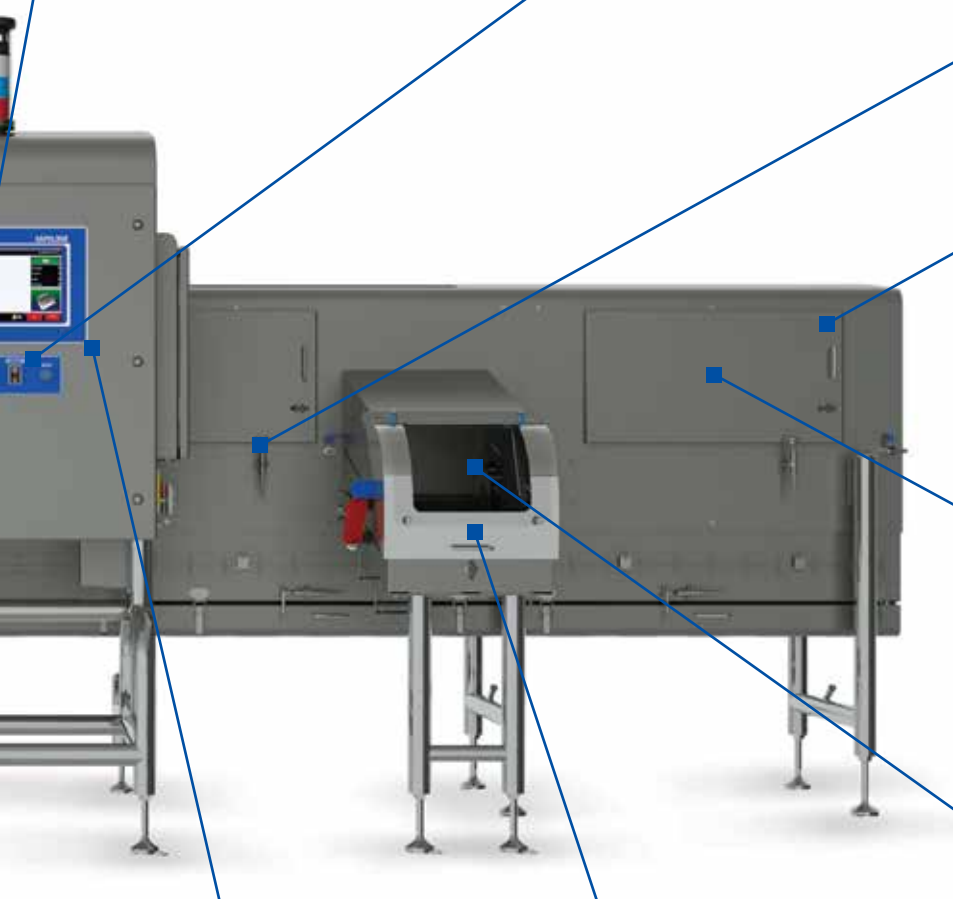

### Large Access Hatches

Improved access for cleaning and product set-up.



### LED Lighting in Tunnel

Provides better visibility throughout the system.



### Robust LED Touch Screen

Suitable for high pressure wash-down (IP69 / Nema PW12).

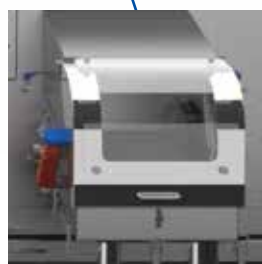

### Lockable Reject With Large-Vision Window

Available on the X3710/20/30, facilitates easier product set-up, demonstrating due diligence.



### High-speed Reject Devices

Ensuring quick removal of faulty products at customer line speeds.

# X37 Applications

## The Big Difference is in Every Detail

The X37 Series of x-ray inspection systems ensures product safety and integrity for a wide variety of tall, rigid containers within the food and pharmaceutical industries.

METTLER TOLEDO Safeline X-ray has many years of experience inspecting a wide range of applications across the food and pharmaceutical industry, such as:

- Infant Foods
- Dairy
- Condiments
- Snacks
- Beverages
- Bakery and Confectionery
- Fruit and Vegetables
- Ready Meals
- Fish and Seafood
- Meat
- Pharmaceutical
- Pet Food

Types of Tall, Rigid Containers:

- Plastic Containers
- Metal Cans
- Glass Containers
- Composite Cans/Tubes/Cartons
- Ceramic Containers
- Doypacks

The X37 Series offers horizontal single-beam and split-beam solutions to cater for different inspection needs and to ensure reliable and consistent inspection for all types of tall, rigid container applications.

High throughput levels of up to 1,200 containers per minute can be achieved, depending on the application. The X37 Series can be installed in to existing production lines without slowing down the customer line speed.

The flexible design of the X37 Series can be fully configured to individual application requirements. With a choice of a 0.4mm or 0.8mm detector, optimum inspection results are achieved, even in the most demanding production environments.

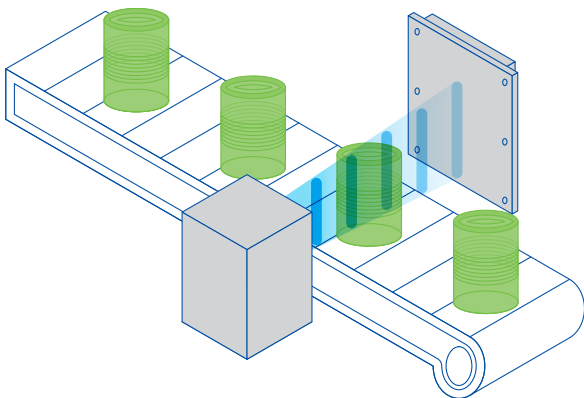

X3710, X3720 & X3725 horizontal single-beam systems

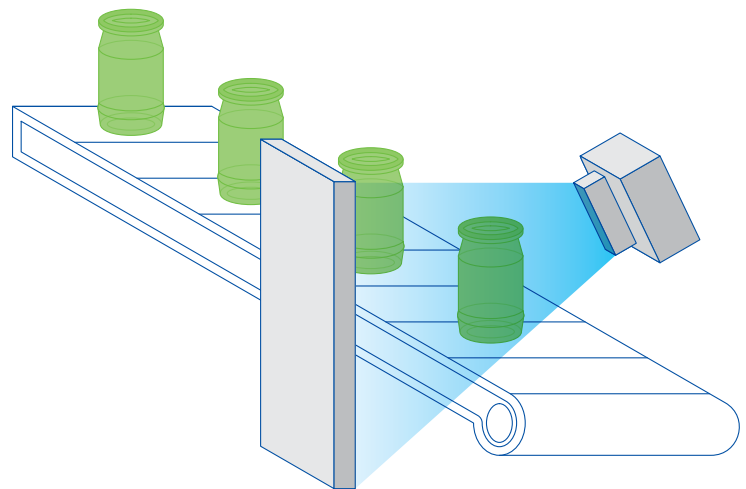

X3750 horizontal angled single-beam system

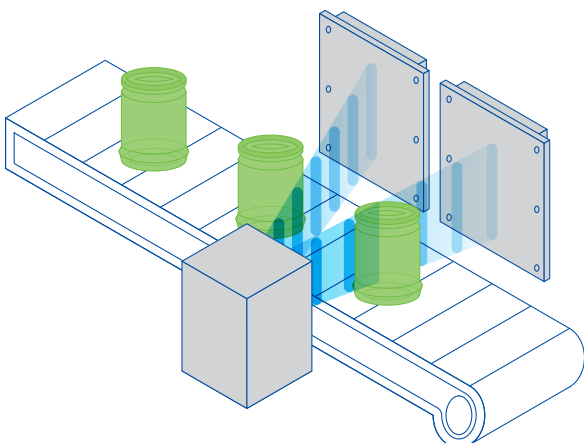

X3730 & X3735 horizontal split-beam system

# X37 Inspection Capabilities

## The Big Difference is in Every Detail

### **X37 Series Product Inspection Tools**

The X37 Series of x-ray systems can detect contaminants whilst simultaneously performing product integrity checks such as:

- Inspecting fill levels and measuring head space
- Detecting missing closures
- Rejecting damaged packaging
- Detecting agglomerates such as flavour and powder lumps

### **Contaminant Detection**

The X37 Series is capable of detecting a wide range of physical contaminants such as glass, metal, calcified bone, high-density plastics and rubber, ensuring product safety.

### **Inspect Fill Levels and Measure Head Space**

The X37 Series is able to inspect fill level and measure head space of each container, minimizing product waste and ensuring product freshness.

### **Detect Missing Closures**

The X37 Series can reliably inspect the presence of caps or lids on containers, ensuring the product is sterile, fresh and without any spillages.

### **Reject Damaged Packaging**

Damaged products on a supermarket shelf can lower a consumer's perception of a brand. The X37 Series can detect damaged products e.g. dented cans and squashed cartons.

### **Detect Agglomerates**

The detection of agglomerates such as flavour and powder lumps ensures consistent product presentation and customer experience.





## Reject Systems

There are a number of different types of high-speed reject systems available to match manufacturers' production needs, while guaranteeing easy and effective removal from the line. The correct choice depends on a number of factors such as environmental conditions, belt speed, pack weight and pack size. The X37 Series has a choice of reject systems with vision windows, lockable bins or driven reject tables.

Safeline X-ray's high-speed reject systems do not slow down the customer line speeds and are capable of rejecting up to 1,200 products per minute, depending on application.

The lockable bin/ reject area ensures due diligence, as only authorised personnel can access the rejected products.

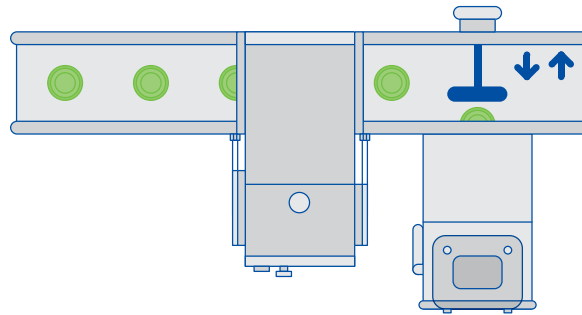

An x-ray system with a **side pusher reject system**, typically used for the rejection of medium and heavy-weight products commonly used on canning and glass-in-glass inspection lines.

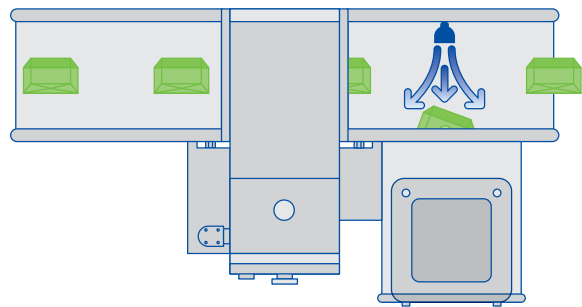

An x-ray system with a **air-blast reject system**, works very well for small and medium packs including doypacks, plastic containers and composite cans and tubes.

# X37 Series Specifications

## The Big Difference is in Every Detail

X37 Features	Specifications	X-ray Inspection Systems					
		X3710	X3720	X3725	X3730	X3735	X3750
Software	Microsoft Windows 64 bit	•	•	•	•	•	•
Casing Material	304 stainless steel	•	•	•	•	•	•
Finish	240 Grit Brushed on main components	•	•	•	•	•	•
Connectivity Options	Ethernet (internal), USB (external)	•	•	•	•	•	•
Conveyor Speed	Typical line speeds 10-120 m/min			•		•	•
	Typical line speeds 10-150 m/min	•	•		•		
Lane Configurations	Single lane applications	•	•	•	•	•	•
Throughput Rate	Typical throughput rates of up to 1,200 products per minute (dependent on product dimensions)	•	•	•	•	•	•
Operating Height	950mm, 1050mm or 1150mm (+/- 50mm)	•	•	•	•	•	•
	1700mm, 2200mm or 3900mm	•					
System Length	4000mm						•
	2000mm, 2500mm or 4200mm		•				
	3000mm or 5200mm				•		
	45000mm			•		•	
Product Height (based on 60mm diameter)	260mm						•
	287mm	•					
	301mm				•		
	303mm			•		•	
	323mm		•				
Cooling Method	20W = Internal Fan	•					
	100W = Air Conditioner		•	•	•	•	•
	420W = Radiator Pump & Air Conditioner		•	•	•	•	•
Screen Display	15.6" LED widescreen (16:9 ratio) display with improved touchscreen	•	•	•	•	•	•
Operating Humidity	Up to 90% RH	•	•	•	•	•	•
Operating Temperature	5 – 40°C	•	•	•	•	•	•
Power Supply	20W & 100W systems only - 110Vac, 50/60Hz	•	•	•		•	
	20W, 100W & 420W - 230Vac, 50/60Hz	•	•	•	•	•	•
Pneumatic Supply	6 Bar(g) clean air supply required for air operated reject system	•	•	•	•	•	•
Traceability Options	Full event log tracks changes of parameters, users and products	•	•	•	•	•	•
X-ray Detector	0.8mm	•	•	•	•	•	•
X-ray Generator	20W, 84kV, 0.25mA Glass or optional beryllium	•					
	100W, 84kV, 1.2 mA Glass or optional beryllium		•	•	•	•	
	420W, 84kV, 5.0 mA Glass or optional beryllium		•	•	•	•	•
X-ray Beams	Single Beam (20W)	•					
	Single Beam (100W & 420W)		•	•			
	Split Beam (100W & 420W)				•	•	
	Single Beam (420W)						•
X-ray Emissions	< 1uSv/hr	•	•	•	•	•	•
X-ray Protections	Fully contained emissions within construction	•	•	•	•	•	•
	Optional lightweight lead-free blue curtains at tunnel apertures on short systems	•	•		•		
Reject Type	Pusher	•	•	•	•	•	•
	Airblast	•	•	•	•	•	
Reject Area	Front mounted lockable reject chute with vision window as standard	•	•		•		
	Integrated driven reject table or take-away customer conveyor			•		•	•
Guide Rails	Adjustable full length guide rails	•	•		•		•
	Product specific guide rails			•		•	
Hygienic Rating	IP65 as standard, upgradable to IP69	•	•	•	•	•	•
UL Approved	Yes	•	•		•		•



### **The X37 Series is Built with Local and Global Standards in Mind**

The seriousness with which the market views product safety issues is underlined by the wide range of national and international legislative and regulatory standards, as well as standards set by retailers. By incorporating appropriate inspection equipment into a company-wide approach to product safety, manufacturers can protect their reputations and meet legal obligations.

The X37 Series x-ray systems give food and pharmaceutical processors the tools to comply with standards such as Global Food Safety Initiative (GFSI) recognized schemes such as the British Retail Consortium (BRC) and International Featured Standards (IFS) or regulations such as the Food Safety Modernization Act (FSMA).

## METTLER TOLEDO Service

METTLER TOLEDO Service wants you to maximise the return on your x-ray inspection equipment through a comprehensive services program consisting of four critical elements:

- **Uptime** - Support & Repair
- **Performance** - Set-up, Maintenance & Preventative Maintenance
- **Compliance** - Quality Assurance & Certification
- **Expertise** - Training & Education



### 5 Year X-ray Generator Warranty

Avoid unexpected costs and production downtime by ensuring the most expensive component of a x-ray system, the x-ray generator is covered.

[www.mt.com/xray-warranty](http://www.mt.com/xray-warranty)

[www.mt.com/xray-x37](http://www.mt.com/xray-x37)

For more information



#### Mettler-Toledo Group

Product Inspection Division

Local contact: [www.mt.com/contacts](http://www.mt.com/contacts)

Subject to technical changes

© 01/2018 METTLER TOLEDO. All rights reserved

PI-XR-BR-EN-012018